

## APC-L10 CONVENTIONAL PALLETIZER LOW LEVEL

### FEATURES

- Simple 5 axis mechanical conventional style action providing very reliable maintenance free operation
- Able to accommodate a wide range of pallet sizes (standard unit will accommodate pallets from 0.8m<sup>2</sup> to 1.6m<sup>2</sup>)
- Bags are stacked within a support frame ensuring stack uniformity
- These units can stack up to 2.3m high for export palletising
- Max palletising rate of 800 cycles per hour
- Versatile machine that can be used for multiple bag sizes, materials and products
- Allows a stack of pallets to be placed in the machine to increase efficiencies by reducing pallet handling operations
- Able to be combined with full automation options such as pallet dispensers, pallet conveyors, pallet wrappers etc
- Very compact space saving design
- Simple intuitive PLC control for ease of use
- Service scheduling and preventative maintenance
- Full technical support and factory trained technicians

### OPTIONAL FEATURES

- Pallet dispensing - optioned automation of pallet feed and discharge increases production and reduces forklift movement
- Pallet Wrapping - full wrapping options from an integral wrapper included in the stacker frame to inline rotary wrapping
- Top sheet applicators
- Conveyers & accumulation - powered pallet systems and accumulation options to suit varying layouts and space availability
- Guarding - complete hazardous area requirements for personnel safety

Reduce labour, downtime and health and safety risks by eliminating manual handling of bagged product. This palletizer uses what's called a conventional style palletizing system. These units are simple, robust, uncomplicated and very effective for applications up to 800 bags per hour.

Aurora's conventional palletizer is very economical when it comes to valuable space. The compact construction means that it can easily replace most manual operations without requiring additional floor space. Its versatile design enables you to feed empty pallets to the palletizer from three sides, increasing options for positioning in your packing area.



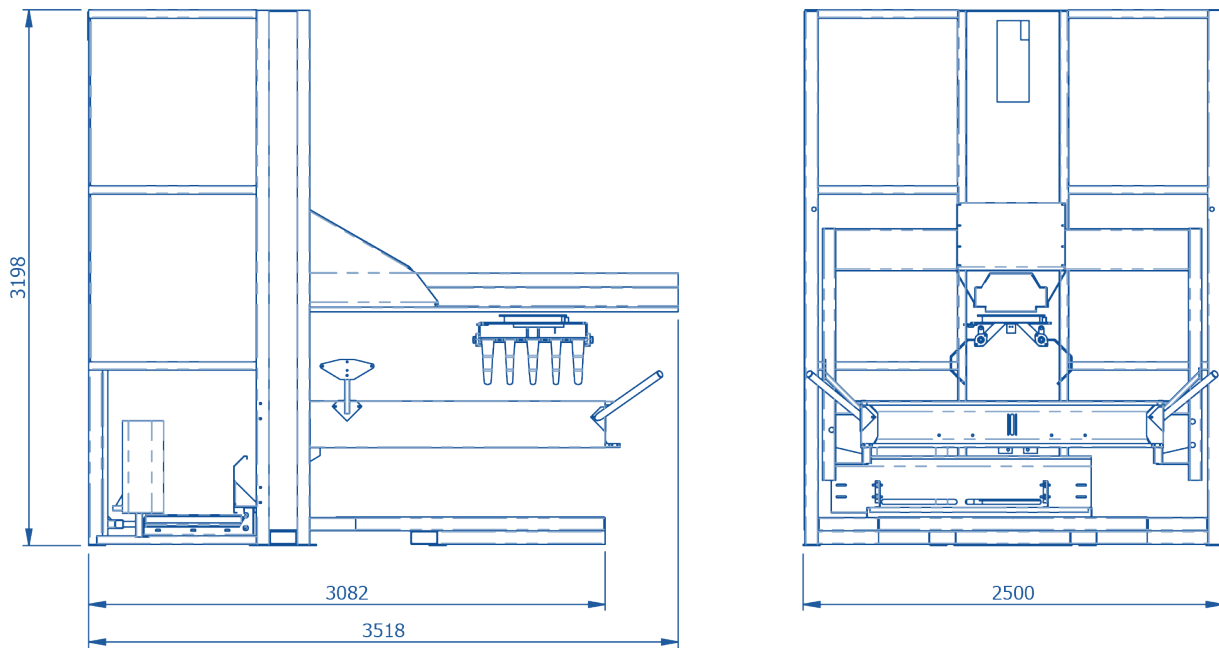

Diagram dimensions are for reference only\*

<b>Dimensions</b>	2500 w X 3518 X 3198 h
<b>Maximum Capacity</b>	Model P625 = 550 bags p/hr Model P825 = 800 bags p/hr
<b>Control System</b>	IPC
<b>Power Supply</b>	230/400 VAC
<b>Powder Consumption</b>	Model P600 = 5.0 kW Model P800 = 7.2 kW
<b>Air Consumption</b>	Model P600 = 60 L/min Model P800 = 120 L/min
<b>Max Working Height</b>	4.2 m
<b>Max Stacking Height</b>	2.3 m
<b>Pallet Size</b>	1200 x 800 up to 1600 x 1200
<b>Bag Weight</b>	10-50 kg