

ILERBAG H HORIZONTAL FFS BAGGING MACHINE

FEATURES

- Up to 1,400 bags per hour
- Total automation of the bagging process
- Quick return on investment
- Optimization of consumables
- Optimized plant space
- Gentle, precise movements during the bagging process
- Easy maintenance
- Versatile configuration to achieve the results you need
- Forms gusseted corner seals

OPTIONS

- Reel entry at 90° to filled bag outfeed
- Thermal transfer printing built in
- Air extraction from inside the bag and/or injection of gas for modified atmosphere
- Seal cooling system with cooled air
- PE mesh conveyors for fine products
- Anti-corrosion versions for corrosive product
- ATEX versions for work in Hazardous Zones
- OEE modules and SCADA systems.
- Product collection systems under the bagging machine
- Mobile platform that moves on rails or wheels
- Hygienic version for food and pharma

APPLICATIONS

- Agri-food: premixtures
- Chemical and petrochemical: plastic granules, PVC, fertilizers
- Construction and mining: sand and gravel, salt
- Recycling: biomass pellets, plastic granules
- Food: dairy powders, flavours, sugar, nuts, flour, ingredients

A fully automated bagging process from making, filling and sealing of the bags in one single bagging machine. The intelligent design of the FFS plastic bagging system uses long tubular reels that requires less replacement of consumables. The standardization of bag formats, by the use of the tubular reel, and the optimization of consumables translate into a significant reduction of the cost per bag.

Space maximization is a key feature of the Ilerbag H. It integrates the bag making, filling and sealing modules in a single unit. This makes it one of the most compact solutions on the market for automatic bagging in polyethylene bags and other heat-sealable compounds. Its design has considered maintenance, eliminating guides and barriers and providing this FFS bagging machine with utmost accessibility. It is also designed for fitting with modules that optimise the results, such as corner heat sealing, corner punching, air extraction from full bags, etc.



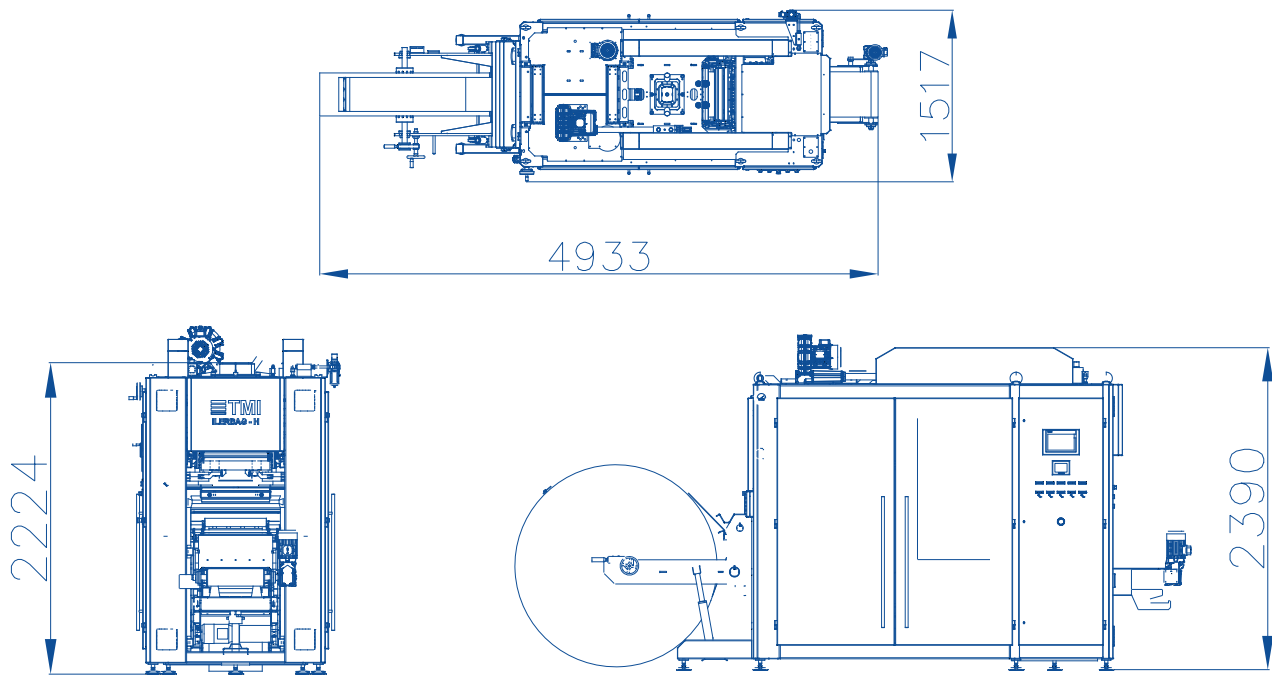

Diagram dimensions are for reference only*

Dimensions	4933mml x 2390mmh x 1517mmw
Power Supply	Voltage: 400v/3P+E Control Voltage: 24v Power: 12 Kw
Pneumatic Supply	Pressure: 6 Bar

FEATURES

- Production of up to 1,400 bags per hour, depending on product characteristics and formats handled
- Bag transfer system with pivoting arms
- Impulse sealing system for the corners
- Patented unwinding with film guide system
- Suitable for PE bags or heat-sealable material on a tubular reel, with or without gussets
- Dosing through gravity, conveyor belt or auger dosers, depending on the product's properties
- Configuration in net or gross weight, depending on the required speed
- Compact unit ideal for small spaces
- Maximum accessibility to all mechanisms for maintenance and cleaning tasks, with all rails and barriers removed
- Removal of all corners and areas where product remnants could accumulate
- Bag compressing systems adaptable to the product and speed
- Simple, intuitive control screen for the operator

Note: Capacity rates can be significantly affected by layouts, product types, and can be confirmed after a detailed analysis of an application.