

## ILERSAC VBF AUTOMATIC VALVE BAGGER

### FEATURES

- Up to 450 bags per hour
- Total automation of the bagging process
- Flexible production
- Optimized bagging of powder products
- Gentle on product
- Dust-free work environment
- Durability, even when handling abrasive products
- Adaptability to high hygiene standards
- Rapid change over between products
- No moving parts in product zone for low maintenance and product protection

### OPTIONS

- Magazine for multiple empty bags for greater autonomy
- Complete enclosure for the entire bagging machine
- Ultrasonic valve closing system model ILERSONIC
- Dust collection systems near the filling spout
- Additional interchangeable filling spouts for different bag formats
- Anti-corrosion versions for corrosive products
- ATEX versions for work in Hazardous Zones
- Multi-fluidisation for heterogeneous mixtures
- Construction in Stainless Steel
- Automatic regulation of fluidisation valves through recipes
- Dosing through knife gate valve and food-grade hose
- Multi-fluidisation for heterogeneous mixtures
- Focused vacuums to minimise dust in the environment
- Soundproofing enclosures for blower
- Safety valve at blower outlet
- Inflatable spout for reduced dust while filling

### APPLICATIONS

- Food: flour, starches, baking additives
- Chemical and petrochemical: PVC, fine chemical products
- Construction and mining: mortars, cements, general minerals

The Automatic Ilersac V Valve bagger is a high-speed unit used to fill a wide variety of powder and granular products into valve bags. Total automation of the bagging process at speed.

Reduce manual inputs and eliminate human error. With outputs up to 1600 bags per hour (450 bags per spout) this filler is well positioned to cover a variety of process size and throughput requirements. The automatic Ilersac V Automatic valve bagger is available fully enclosed for ultimate dust control with the added benefit of a small footprint.



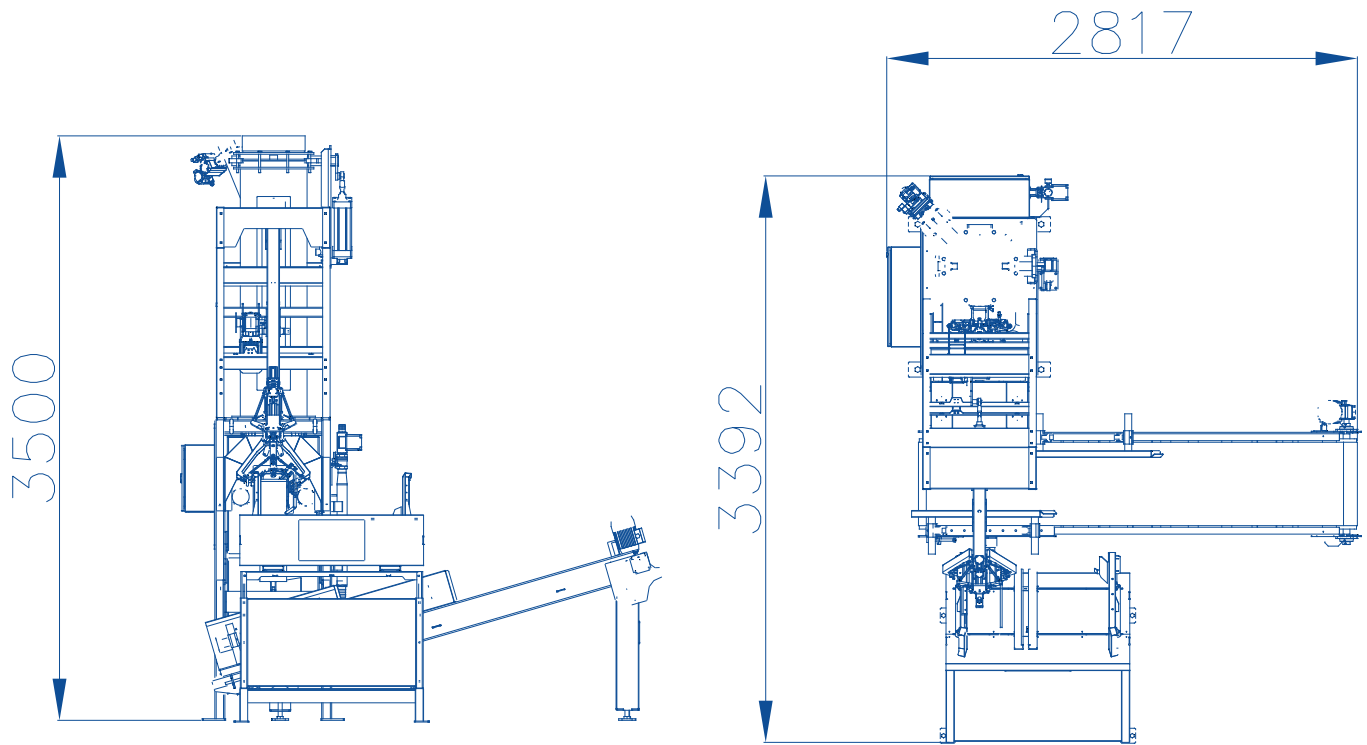

Diagram dimensions are for reference only\*

|                         |  |
|-------------------------|--|
| <b>Dimensions</b>       | 2817mm x 3500mm x 3392mm                                   |
| <b>Power Supply</b>     | Voltage: 400v/3P+E<br>Control Voltage: 24v<br>Power: 5.5Kw |
| <b>Pneumatic Supply</b> | Pressure: 6 Bar  |

## FEATURES

- Production of up to 450 bags per spout per hour
- Suitable for paper valve bags
- Dosing through product fluidisation (pneumatic conveying) and pinch valve
- Sections without corners or mechanical elements for quick cleaning when changing product
- Dust collection outlets to be connected to the filter
- Filling spout with pneumatic bag holding system
- Simple, intuitive control screen for the operator
- Approved MID Class 0.2 weight controller
- Rotary piston blower
- Motorised tangential bag placement system
- Bag valve opening system built into the bag placer arm
- Simple empty bag magazine
- Operation through work recipes

Note: Capacity rates can be significantly affected by layouts, product types, and can be confirmed after a detailed analysis of an application.