

ILERBIG H SEMI-AUTO BULK BAG FILLER

FEATURES

- Up to 60 bulk bags per hour
- Hygienic design prevents cross-contamination
- Easy, quick cleaning process
- Long-lasting components
- Easy maintenance
- Ergonomic design for the operator
- Dust-free work environments
- Optimized productivity
- Reduced cycle times
- Stability when the bulk bag is full
- Flexible configuration
- Weight control at all times
- Ability to double stack bags
- Handles a wide range of bag sizes
- Compatible with single and four loop bags

OPTIONS

- Vibration from below working in combination with the hydraulic lift system to ensure the product settles properly
- Anti-corrosion versions for corrosive products
- Special versions for food industry and hygienic environments
- ATEX versions for work in Classified Zones
- Turbine to inflate bag
- Automatic pallet infeed and outfeed through rollers or belt-driven rollers (palletless)
- Cardboard sheet dispenser for empty pallets and/or loaded pallets
- PE sheet dispenser from the roll for empty pallets, with stapler for securing

APPLICATIONS

- Agri-food: seeds, grains, animal feed, pet foods, premixtures, etc
- Food: sugar, flour, powdered milk, cocoa powder, starches, ingredients, chocolate
- Chemical and petrochemical: PVC, fine chemical products
- Construction and mining: mortars, cements
- Recycling: pellets, recycled plastic, biomass pellets, compost, shredded tyres

The Ilerbig H is a bulk bag filling system designed for optimized productivity and operator ergonomics. A single operator can handle the filling station, from the positioning of the bag, to its removal. This units height adjustment capacity, tilting filling spout and its mobile hooks for bag fastening provides easy operation. This also provides reduced cycle time boosting throughput rates.

The intelligent design handles 4-loop and single-loop bulk bags, on pallet or directly on conveyor belts. It is also designed to prevent product residue lodging in the filling lines, thus avoiding contamination between cycles, as it also allows an easy and quick cleaning process.



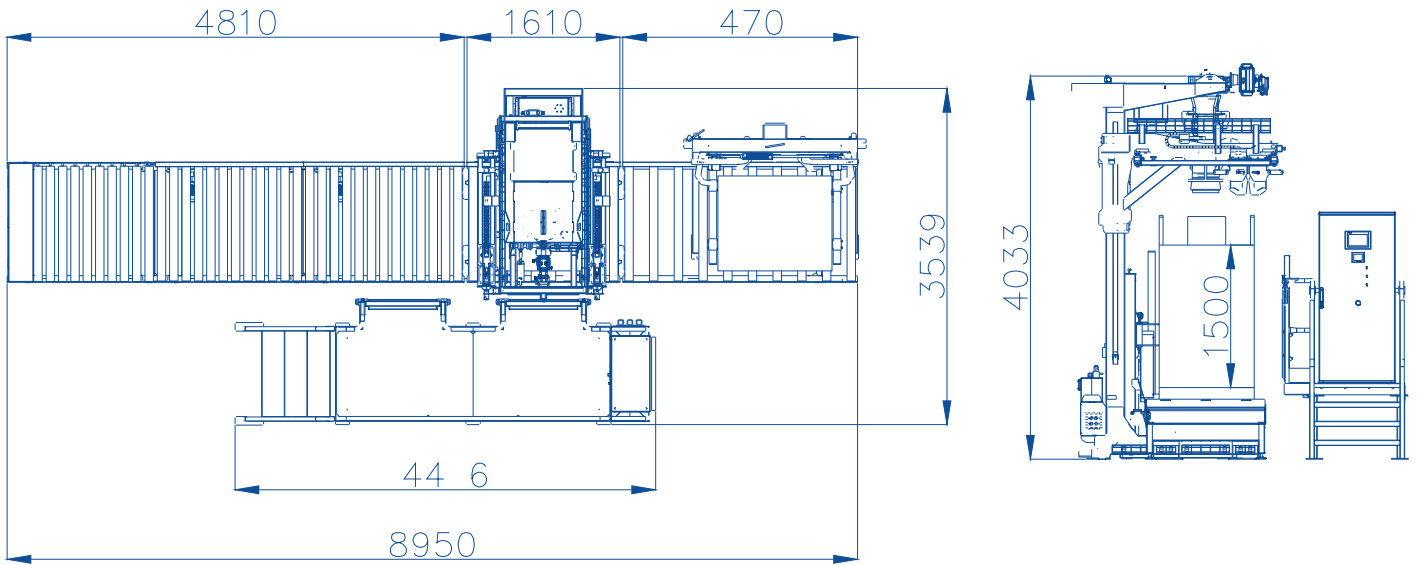

Diagram dimensions are for reference only*

Dimensions	8950mm x 4033mm x 3539mm
Power Supply	Voltage: 400v/3P+E Control Voltage: 24v Power: 7 Kw
Pneumatic Supply	Pressure: 6 Bar Consumption: 100 NI/Min

FEATURES

- Production of up to 60 bulk bags per hour, depending on product characteristics, formats handled and line operator's speed
- Dosing through gravity, conveyor belt, auger doser or another method, depending on the product's properties
- Configuration according to gross or net weight, depending on production
- C-type structure for a clean, accessible solution
- Hydraulic lifting system lifts full bulk bags to ensure the product settles properly
- Double weighing system through load cells on hooks and support platform
- Automatic height adjustment through flexible, food-grade channel
- Pneumatic hooks with linear movement for better line operation ergonomics
- Flexible filling chute with no joins or telescopic mechanisms, approved for use with foods
- Inflatable filling spout with adjustable height to make it easier for the operator to place the big bag
- Pneumatic filling spout to prevent product leaks during the filling process and accumulations of dust around the bulk bag filler
- Approved MID Class 0.2 weight controller
- Configurations for bulk bags with 4 loops and 1 loop
- Platform for operator with presence system and safety measures

Note: Capacity rates can be significantly affected by layouts, product types, and can be confirmed after a detailed analysis of an application.