

ILERPAL W HIGH-CAPACITY AUTOMATIC PALLETIZER

FEATURES

- Up to 1,500 bags per hour
- Open-mouth bag overlapping at high production levels
- Optimal finishes at high production levels with open-mouth bags
- Load stability on the pallet
- Flexible, versatile format changes
- Gentle, quiet, precise palletizing
- Energy savings
- Palletize tall stacks up to 2700mmh
- 5 Sided Layer Forming & Pressing

OPTIONS

- Cardboard sheet dispenser for empty pallets and/or loaded pallets
- PE sheet dispenser from the roll for empty pallets, with stapler for securing
- Side forming with extraction gates
- Tackle to make changing rolls easier
- Anti-corrosion versions for corrosive products
- ATEX versions for work in Classified Zones

APPLICATIONS

- Agri-food: seeds, grains, animal feed, pet foods.
- Food: sugar, flour, pulses, nuts
- Chemical and petrochemical: plastic granules, fertilizers
- Construction and mining: sepiolites, salt

High capacity high-level layer forming palletizer for overlapping bags. This unit provides excellent pallet presentation. Its palletizing gripper runs alongside a telescopic bag delivery belt, unloading each bag exactly where it should be placed and allowing precise high-speed overlapping bag stacking.

Producing stable pallets, even with products that are difficult to stack, thanks to the lateral and upper conformation of each layer.

The ILERPAL W's intelligent design allows for rapid bag format changes in a range of 5 to 50 kg without any adjustments.

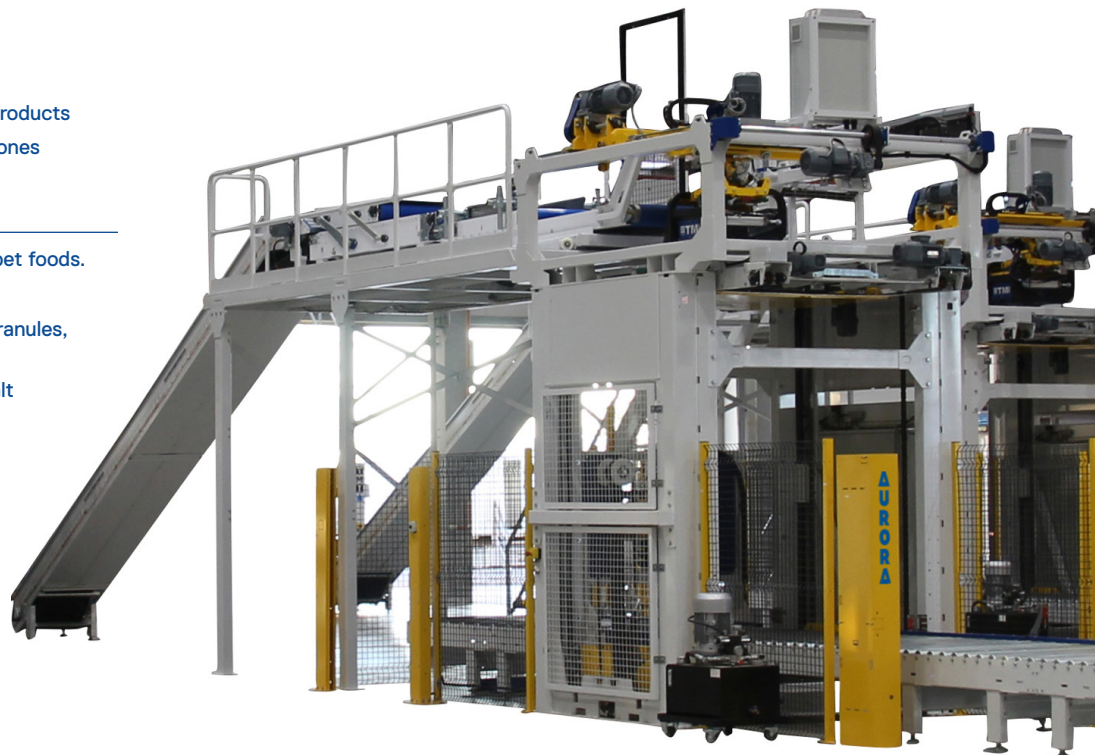

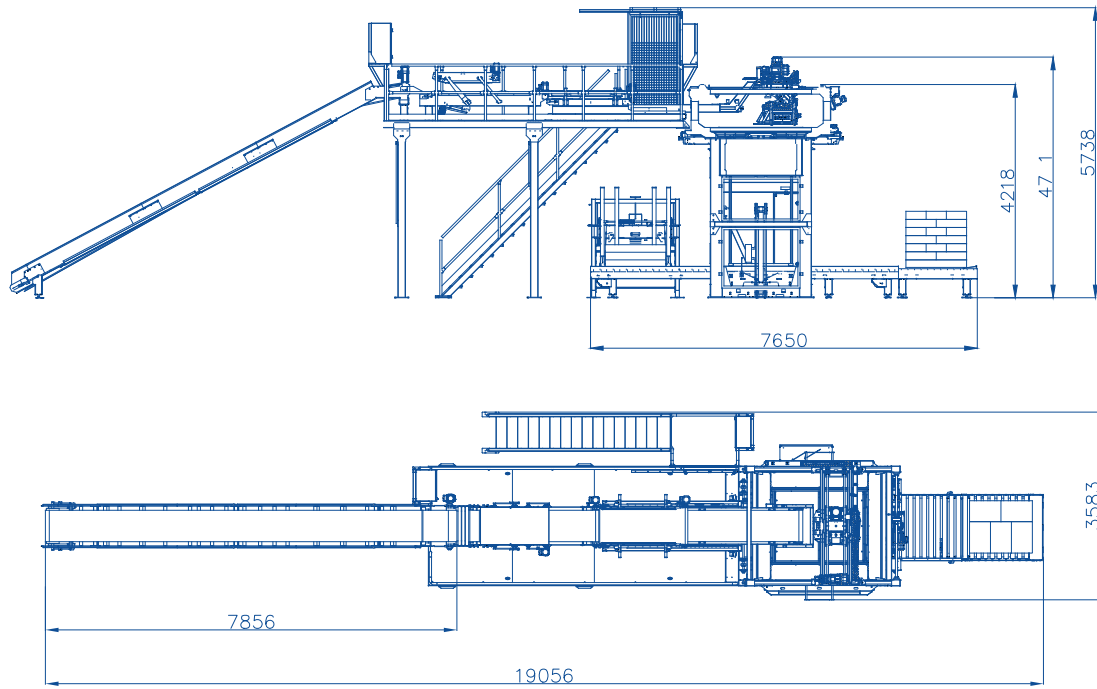

Diagram dimensions are for reference only*

Dimensions	19056mm x 5738mm x 3583mm
Power Supply	Voltage: 400v/3P+E Control Voltage: 24v Power: 26Kw
Pneumatic Supply	Pressure: 6 Bar

FEATURES

- Production of up to 1,500 bags per hour with open-mouth bags
- Synchronised open-mouth bag gripper head for greater precision and a tilted shape to load and unload bags more quickly
- The infeed conveyor is telescopic and moves with the gripper, so that any unnecessary movement is avoided and production gains and energy savings are made
- Double layer-forming gate with bag sweep areas coated in polyethylene (PE-1000) to slide the layers onto the pallet more smoothly
- Motorised side forming guides, driven by a double rack-and-pinion mechanism
- Top layer compaction system, consisting of pushing each layer against the top floating platforms using the lift platform
- Pallet centering on the lift platform
- Hydraulic pallet lift platform
- Main frame compact enough to allow for sending in a conventional shipping container
- Touch screen for simple, intuitive configuration

Note: Capacity rates can be significantly affected by layouts, product types, and can be confirmed after a detailed analysis of an application.