

APW-R SERIES RING PALLET WRAPPER

FEATURES

- Increased load balance
- Less mechanical wear than turntable wrapper
- Less maintenance than other wrapper types
- Film tail cut and weld
- Electronic and self-adjusting wrap tension control, up to 300% pre-stretching
- Wrap to ground level
- Very compact space saving design
- Simple intuitive PLC control for ease of use
- Service scheduling and preventative maintenance
- Full technical support and factory trained technicians
- Film Roping options

OPTIONAL FEATURES

- Wrap roping device
- Motorized top hold down plate
- Top sheet applicators
- Conveyors & accumulation - powered pallet systems and accumulation options to suit varying layouts and space availability
- Guarding - complete hazardous area requirements for personnel safety
- Automatic film roll changer

Rotary ring stretch wrappers for wrapping pallets. Low maintenance and very intuitive to operate. Used across industry due to the ranges robust and intelligent design and intuitive operation.



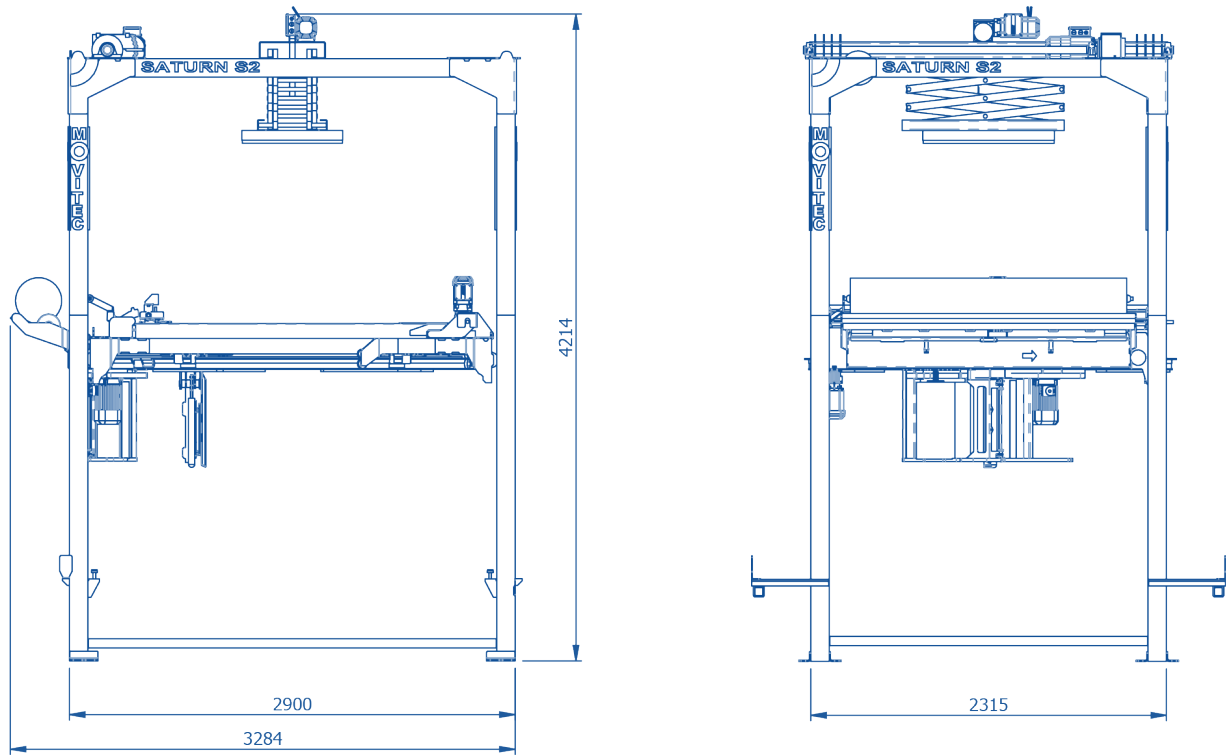

Diagram dimensions are for reference only*

Dimensions	2315 w x 3284 x 4214 h
Maximum Capacity	Model S6 = 120 pallets p/hr Model S8 = 160 pallets p/hr
Control System	IPC
Power Supply	400v/3 Phase + E
Air Supply	6 bar
Stretch Wrapping Film: Max Width	500mm
Stretch Wrapping Film: Max Diameter	300mm
Stretch Wrapping Film: Core Diameter	76mm
Stretch Wrapping Film: Thickness	Up to 35 micron