

## CB10

### Continuous Band Heat Sealer

#### FEATURES

---

- High bond seal for zero leakage
- Stainless Steel 304 construction
- Seals gusseted bags
- Up to 14mm high seal line
- Cooling function
- Temp control to 0.4 deg C
- Up to 24m/min sealing speeds available
- Self Aligning heading bars – reduces set-up
- Low-Profile Infeed Ensures Correct Bag Presentation
- Electric height-adj column for different bag heights
- Fixed Height Flat Belt Closing Conveyor 2600 x 400mm
- Delivered pre-commissioned

#### OPTIONS

---

- Left to Right operation
- Mobile Pedestal Base
- Different length conveyors
- Ink Jet printer

Intelligent and easy to operate. The CB10 provides an excellent high-integrity seal across a large range of bag materials and thicknesses.

Dual heating elements with independent controls allow a high degree of adjustment of the sealing configuration.

The CB10 is a reliable workhorse that gets the job done.



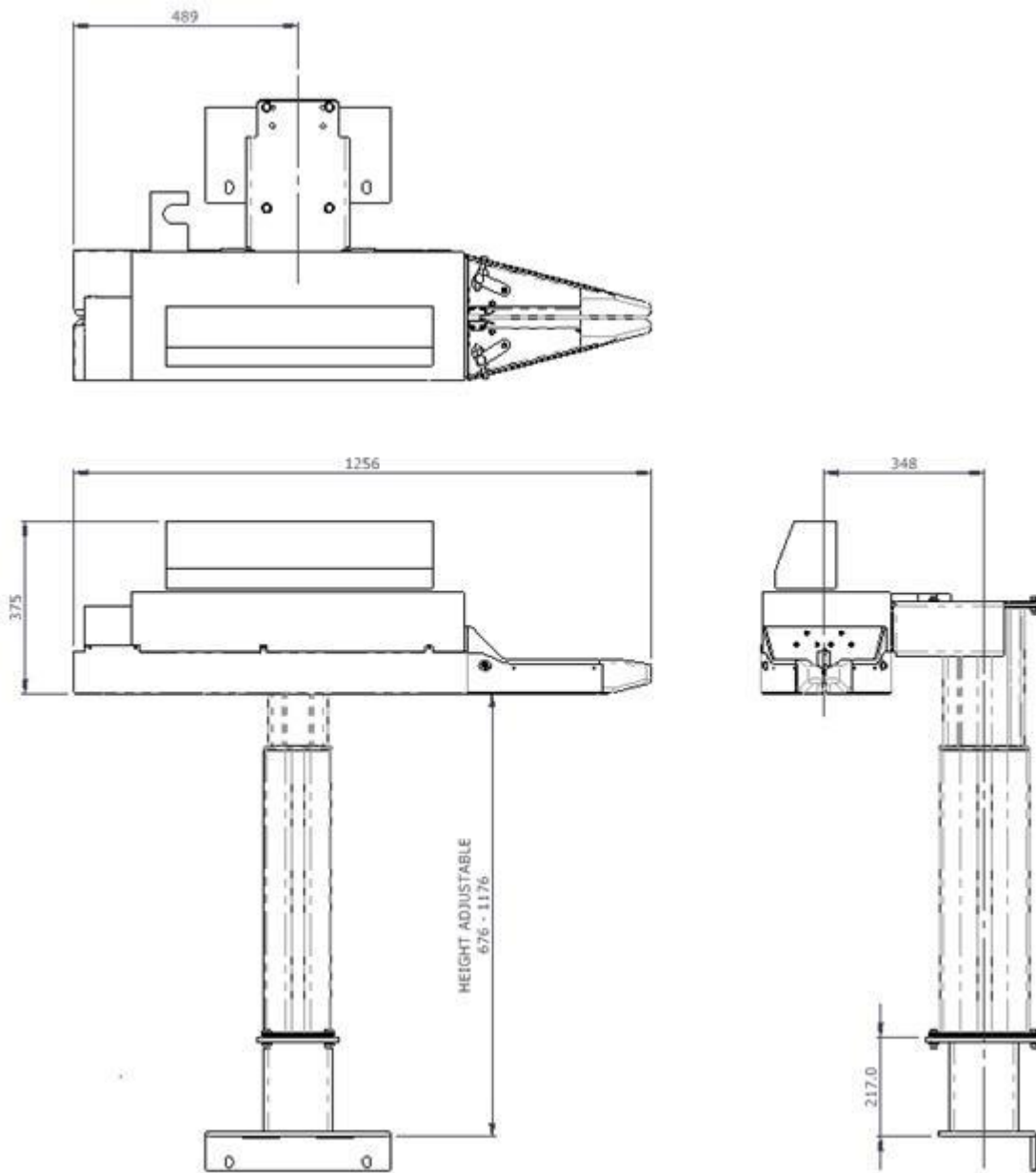

Diagram dimensions are for reference only\*

---

**CAPACITY** 22 meters per/min

---

**BAG TYPE** Seals Thermo-Weldable, Pillowstyle, Polyethylene Bags & Pouchs

---

**INDUSTRY** Dairy, Fertilizer, FMCG, Food, Landscape Products, Medical, Milling

---